

FS3IRC-85

Compact Remote Repeater Unit (RRU)

- 806-869 MHz Frequency Range
- +25 dB Gain
- Compact Size
- Low Noise & High Dynamic Range
- Fault-Over-Fiber Feature
- Optional Wavelength Division Multiplexing (WDM)



RF on Fiber® technology offers a new and flexible layer to traditional Distributed Antenna System (DAS) design. Fiber optic cable is not only less expensive to purchase and install than its coaxial counterpart, but it is virtually bandwidth unlimited, making it ideal for multi-service solutions and applications where long runs of coax become cost prohibitive.

This 800 MHz SMR band product is ideal for applications requiring RF coverage extension into areas ranging from 50,000 to 100,000 square feet. The duplexed RF port can be used to interface to a single indoor antenna, or a traditional signal distribution system with multiple-antennas. Up to 32 RRU's can be deployed to create a reliable wireless communications service area of

1,000,000+ square feet. The FS3IRC family of products can be successfully implemented for both in-building and campus wide environments.

The FS3IRC-85 Compact Remote fiber optic Repeater Unit (RRU) is part of Fiber-Span's FS3IRC family of products and is designed to deliver > +20 dBm of base-to-portable output power in the 800 MHz SMR band. It features an integrated high dynamic range fiber optic transceiver, a high gain, low noise Power Amplifier, and high Q ceramic filtering with duplexed RF port. Consult Fiber-Span Sales for other filter configurations.

As depicted in the diagram below, a Fiber Transceiver Unit (FTU) is required to perform the RF-to-optical conversion at the headend. The FTU can be

ordered in 1-port, 2-port, or 4-port configurations for supporting up to 4 RRUs. Multiple FTUs can be used to support any number of RRUs. Refer to data sheet DS3IF-01 for determining which FTU model number best fits your application. Consult Fiber-Span Sales for assistance in determining whether an Headend Repeater Unit (HRU) or Base Station Interface Unit (BSU) may be required for your application.

All of Fiber-Span's FS3IRC series RRUs come standard with a Fault-over-Fiber feature that sends a summary fault condition over the uplink fiber path to the headend Fiber Transceiver Unit (FTU). The summary fault condition appears as a dry contact relay at both the back panel of the FTU, and as a local alarm to the RRU.

Applications:

- In-building
- Shopping Malls
- Warehouses
- Parking Garages
- Airports
- Justice Centers
- Manufacturing Facilities
- Stadiums
- Convention Centers
- Universities

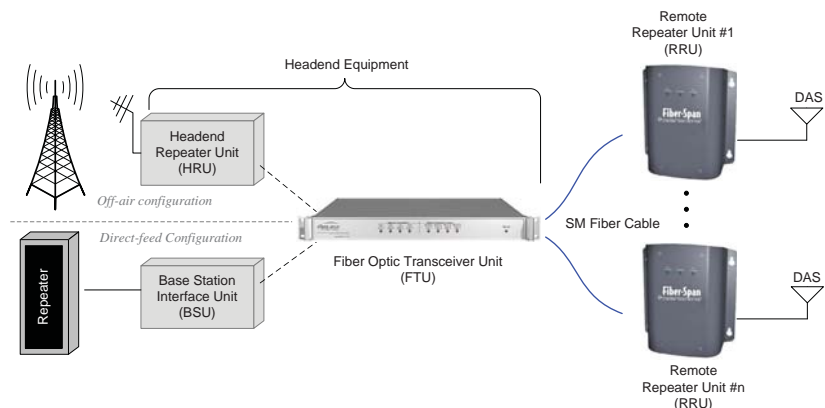

Fiber-Span is a world-leading manufacturer of RF ON FIBER® Communication Network Products for in-building, in-tunnel and outdoor coverage extension systems serving the Commercial Wireless, Public Safety, Government and Military markets.

Parameter	Downlink	Uplink
Operational Range	851-869 MHz	806-824 MHz
Available Bandwidth	18 MHz	18 MHz
System Gain @ 4 dBo optical path loss ¹	+25 dB	0 to +10 dB
Composite Output Power	> +20 dBm	n/a
Gain Reduction (manual)	20 dB continuous	n/a
Max. RF Input Level	n/a	-10 dBm no damage
Uplink Noise Figure	≤ 10 dB (@ max gain & < 1 dBo)	
Wideband Noise (dBm/Hz)	-106 dBm/Hz @ max gain	
Max. RF Output Power (per 25 KHz FM Channel)	1 Carrier: +20 dBm, 2 Carriers: +17 dBm, 4 Carriers: +14 dBm, 8 Carriers: +11 dBm	
Spurious Emission	< -13 dBm	

¹ Depends on Headend FTU configuration.

Environmental

Operational Temperature Range	-5 to +50 deg C
Humidity	10 to 95%

Fiber Optic Parameters

Wavelength	1310 nm
Laser type	DFB
Max. Optical Budget	Downlink: 4 - 10 dBo ² Uplink: 10 dBo
Fiber Optic Cable Type	Single-Mode 9/125um
Connector Type	SC/APC
Back Reflections	< -50 dB typ.

² Downlink fiber optic link budget is dependent on headend FTU configuration.

Electrical

AC Power	50/60 Hz, 115-230 VAC
Power Consumption	< 30 Watts
Local Alarms:	Dry Contact Relay ³
Remote Alarms:	Summary Fault sent to headend FTU over fiber. ³

³ Dry Contact Normally Open = OK

Mechanical Specifications

Dimensions (W x H x D) inches	8 x 12 x 3 (approx.)
Weight (approx.)	< 8 lbs.
RF Connector Type	N-Female

Ordering Information

Identification Part Number

FS3IRC-85

FS3IRC-85X

Where: X = W or N (see WDM table)

WDM - Wavelength Division Multiplexing

W = Tx & Rx signals are multiplexed onto a single fiber.

N = Tx & Rx signals are on separate fiber strands.

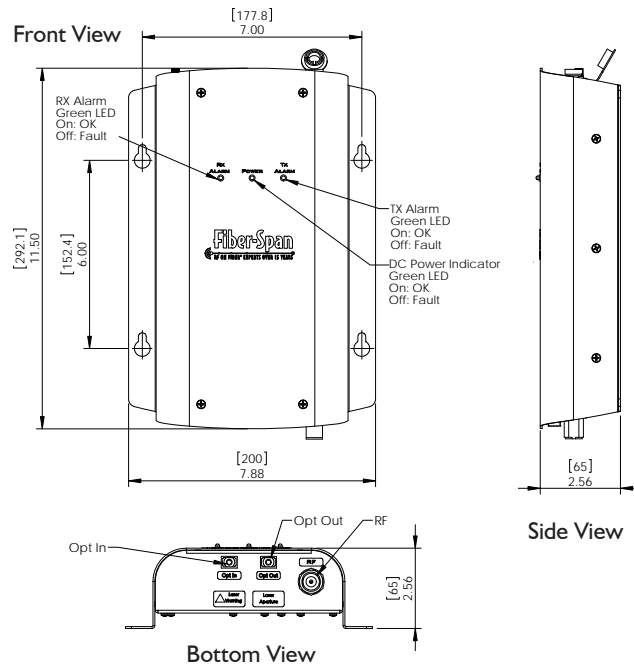

LITERATURE ORDER CODE: FS3IRC-85-01-0708v2